

The 2nd CIB W78 + W74 Seminar
COMPUTER INTEGRATED CONSTRUCTION
September 17th-19th 1990, Tokyo, Japan

MODEL FOR ARCHITECTURAL SPACE

By Masamichi Iwai*, Yuji Tsukuda*, Fumihiko Yamada* and
Takashi Arai*

ABSTRACT

The most important theme for future computer-utilization is to modelize buildings and to use the information-data in various ways. The modeling of buildings had been very difficult because of its complexity, and abundant amount of data. However with the COMPASS system, which we developed, Space, which is the most unique element in Architecture-Designing, is put into the center of Data-Structure. It saves work, allows manipulation of the character data, modelizes efficiently and output's data automatically. In the followings, we will describe the details of the COMPASS system.

1. INTEGRATION OF BUILDING-PRODUCTION INFORMATION

Computer usage has spread throughout the design process, and it is necessary to unify the data processing systems. The object of integration is quality control, reduction of operating hours, costs, etc. and the key to achieving it relies on improvements information control. The previous system which mostly relied on paper sketches has become a block, causing difficulties in data processing. The sketch once developed restricts free and smooth communication causing mistakes and waste of time and money. Using a general model of architecture, described in computer data bases, the information needed for each stage of the design can be selected from the data without delay. This allows 3-D visualisation, automatic drafting, analysis, grouping and selecting of information. Compared to the previous sequential system, this allows simultaneous, parallel designing and studies of construction documents to achieve a rationalized system.

* Chief Engineer: Technical & Design Department,
Fujita Corporation

2. TOTAL FLOW OF INFORMATION

The information flow process consists of the designing stage, the construction stage and the maintenance stage. The design stage includes programming, development, and construction documents. To systemize the process, it is necessary to make these stages in to process with a changeable structure linked to architecturally related information. During the design stage, the model making process is a process of TRIAL AND ERROR, by which the shape is formed through 2-D and 3-D visual design checks plus mathematical analysis. In this stage a system that helps recognition is formed; once the system is formed, the subsequent process for the production can be done automatically.

3. CONDITIONS FOR THE MODELING SYSTEM

The followings are needed in a good modeling system.

- A special language for designers and symbolic marks for operation,
- A wide range of descriptions and definitions,
- Utilization and preservation of architectural knowledge (intellectual management),
- Fast response, data preservation, expansion and compatibility of the system,
- Storage ability of large information files which can be shared by many people.
- A flexible system that is easily modified,

Since it is very difficult to find an adequate program, we have developed an original architectural modeling system called COMPASS, which is based on architectural "space of a room".

4. SUMMARY OF THE SYSTEM

COMPASS consists of three systems - the information input and output systems, the architectural data base system. These systems are organized by a system monitoring program, which handles basic processes such as the dialogical process or data base/program control, and these were introduced from the basic program "CADEL" by Japan IBM. (Fig.-1)

5. MODELING OF ARCHITECTURE

The modeling of buildings is done through the following process.

- 1) Scaling: Arranging the scale of the span, stories etc.
- 2) Listing: Arranging the elements used for the building. By using the general data programmed beforehand into the sub-system, this process may be omitted.
- 3) Floors: Arranging per floor each component such as frame members, walls, door and window, the room image and other parts. The inputting process is made more efficient by using default and automatic-definitions of architectural rules.
- 4) Siting: Arranging the site, the roads and placing the buildings. There may be many buildings on the site.
- 5) Listing of details: In the primary stage of designing, modification of default information is determined.
- 6) Floor details: Information of details may be changed individually.

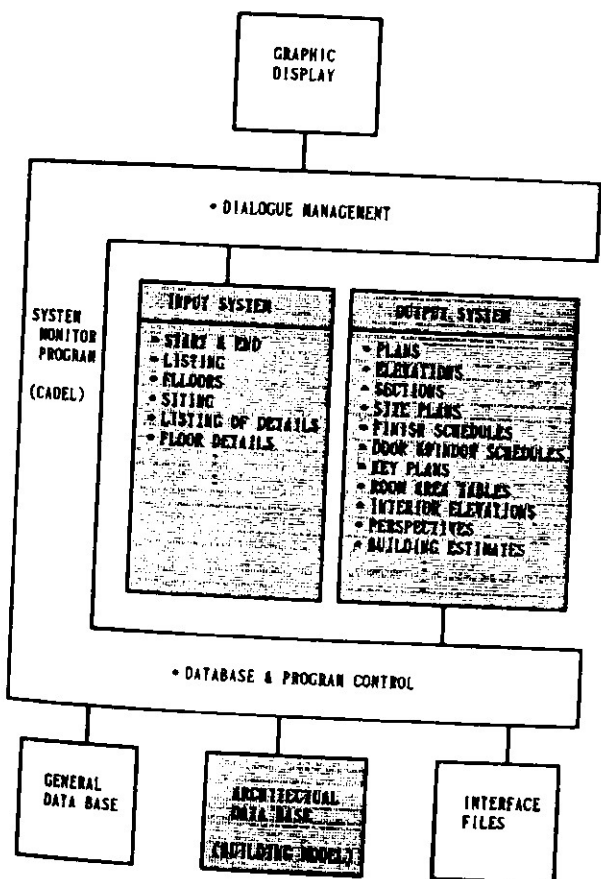

Fig-1. SUMMARY OF COMPASS SYSTEM

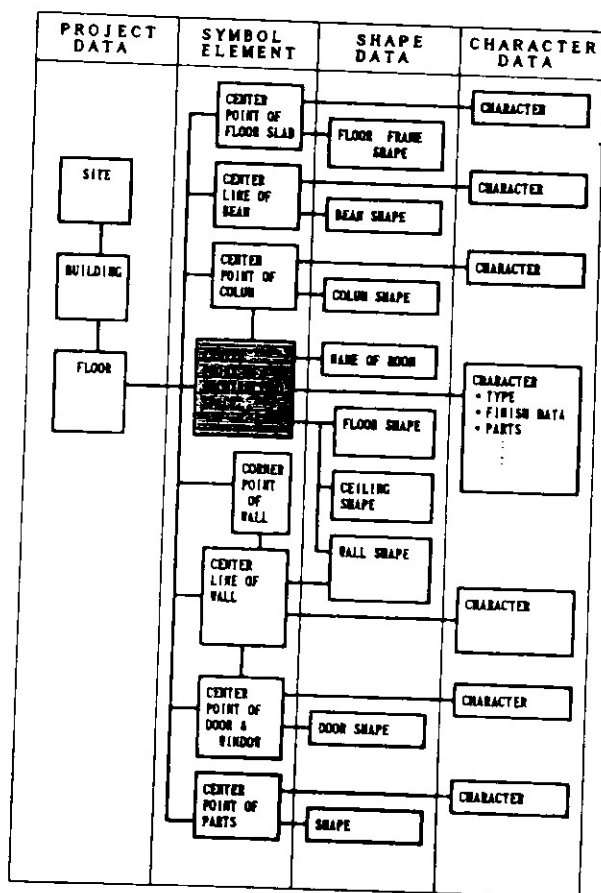

Fig-2. DATA STRUCTURE FOR ARCHITECTURAL SPACE MODEL

6. DATA STRUCTURE

The building, which is of a 3-D structure is managed on each floor in 2-D form. Therefore input is generally done in 2-D. The system is operated using symbolic elements such as points and lines, and the concept of the building is classified as follows: (Fig. 2)

1) Structural Elements

Columns, beams and floor slabs, etc., are located around the grid and can be placed automatically, it is possible to use the data also for a structural analysis model.

2) Walls

The role of the walls is to change open space into enclosed domains. There are no rules as to where they should be placed, but it is very difficult to set their exact location. To do so, it is necessary to use a design system which enables sketches of supporting dots and lines through a cut-in function, defining the center line of the wall. In the process, data on the joints of the walls would be accumulated. Furthermore, the type, material, and width, etc., of the wall can be modified. For walls in general, there is a selection of full walls, wainscot walls, down walls, parapets, false walls, etc. False walls are used when it is impossible to make a closed loop or when it is necessary to divide the area. Special walls, curtain walls, partitions, and handrails, etc., are available.

3) Door and Window Schedule

The doors and windows are connected with the wall and will all be removed when the walls are replaced. Basic information such as the doors' shapes, materials and size, are selected automatically, and are arranged on the walls by using supporting dots and lines.

The detailed information needed for the door and window schedule is automatically selected from the basic information and modifications for each part can be made, using a detailed list of selections. By framing and arranging with supporting dots and lines, various and complicated schedules can be defined also.

4) Space

An area enclosed by walls is called a room and each room is described by its specific name. When the rooms are arranged after the walls are set, their components are recognized through an automatic search for enclosed space. This is accomplished by using the connections of the center lines and corner points of the walls, and directly linking the shape of the room with the grid patterns.

The character of the room, such as its final shape or enclosed space, is automatically arranged when the room-types are decided.

As mentioned above, a feature of this system is that it saves work and allows manipulation of the characteristic data of buildings.

5) Parts

Unit bathrooms and sinks or kitchens are placed individually. Parts are registered in subsystems of 2-D or 3-D bases, and can also be defined in fixed or variable forms. Data concerning classifications, names, purposes, shapes, and characteristics etc. is unified, and output descriptions for any object is coordinated.

7. SUBSYSTEM

The definitions and arrangements of the architectural components are done by modelization. The data information consists of standard information and original information, and are controlled under subsystems, such as the project managing system, standard data managing system and components managing system. The standard data managing system controls information on general matters, such as materials, names and numerical values, etc. Further expansion of the system is being planned.

8. OUTPUT

The buildings are easily modeled by means of the methods mentioned above. By using the modeled building data, the plans, elevations, sections, site plans, finish schedules, door/window schedules, key plans, room area tables, interior elevations, various kinds of exterior/interior perspectives and building estimates can be automatically shown on the system. These are based on the integrated model. The coordination of all the output data in the above model is reciprocally available. Therefore, every drawing and perspective can be changed instantly changing the modeling data. Drawings made automatically by using the modeling data can be modified and preserved, and information can be added on the drawings by means of the drafting system. Data for exterior and interior 3-D perspectives is also prepared automatically by using the modeling data, and the data is transmitted to high-resolution intelligent terminal. The various simulations of the perspectives, colours, materials, light and movement are available by using the various renderings. Furthermore, animation is possible with an automatic VTR.

The object of "building estimation" is cost-planning at the design stage, and the total building costs can be estimated by a simulation system using the modeled data. The structural concrete volume, forms' quantities and finishing material quantities in

every room can be estimated automatically as precise values from the modeled building. Temporary works, foundation works, earth works, site works mechanical and electrical works and the various costs which are not modeled, are estimated by multiplying the unit value by the estimated quantity in the modeled works. The finishings of each part can be described by a division of a maximum of five layers, and the building estimation can be obtained by multiplying the combination unit price and the partial area applied. It is therefore very easy to simulate changes in finishing materials. (Fig.-3)

9. PLANS FOR THE FUTURE

What has been mentioned so far is an outline of COMPASS. However, it is not able to describe drawings with complicated patterns. Therefore, it is necessary in the future to develop a system for the treatment of specific figures and members, databasing of parts and members, and use of Artificial Intelligence.

Above all, an accumulation of information regarding the space cannot be omitted for an intelligent treatment. The names of the rooms represent the image of the space. For instance, if we refer to the reception room of an office, we would immediately imagine its area, shape, furniture, finishing materials, installations, legal limitations, environmental conditions, etc. When you design the space, it is necessary to study the actions of the person who lives there, in both physical/objective and mental/subjective evaluations. The above architectural modeling method, plus accumulation and usage of this knowledge is a very important theme.

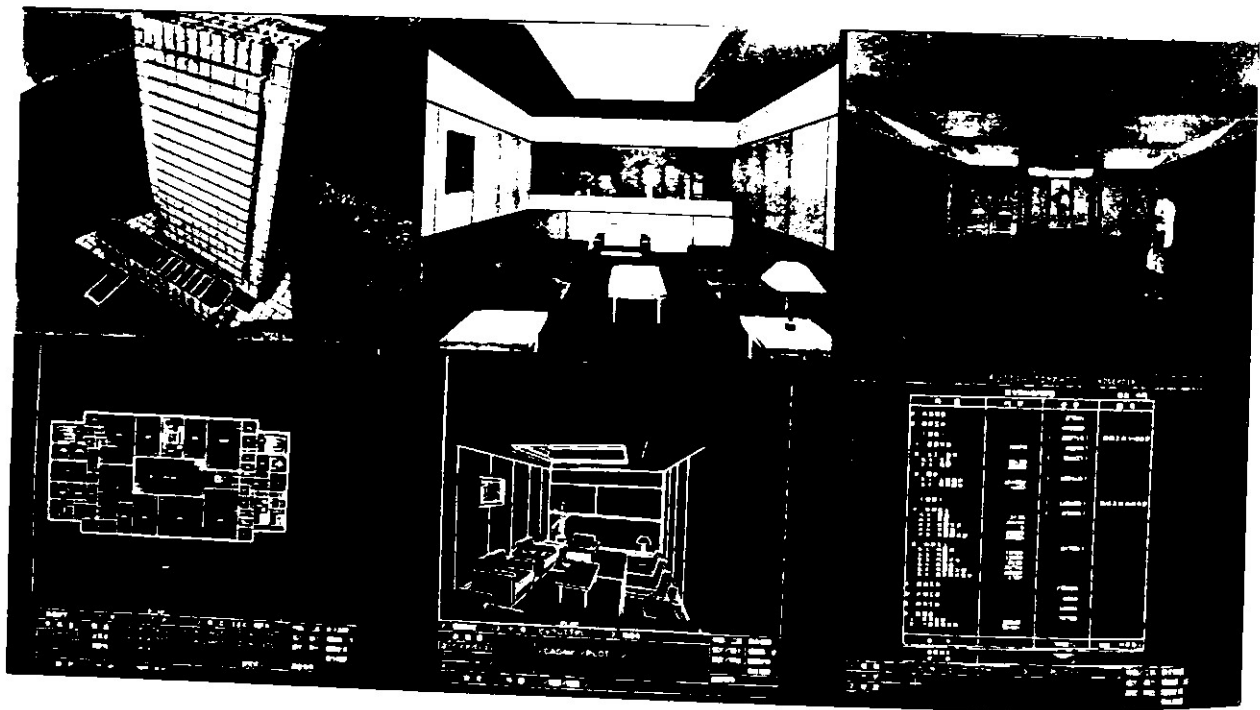

FIG-3. OUTPUT EXAMPLES OF COMPASS